

BV-05-47



Válvula de Compuerta Extremos roscados



Marca	Denominación	Nº piezas	Material	Norma
1	Cuerpo	1	EN-GJS-500-7 (GGG-50)	EN 1563
2	Tapa	1	EN-GJS-500-7 (GGG-50)	EN 1563
3	Cierre	1	Latón/ EN-GJS-500-7 (GGG-50)*	CuZn40 Pb2/EN 1563
4	Revestimiento del cierre	1	EPDM	EN 681-1
5	Eje	1	X20 Cr13	EN 10088
6	Junta cuerpo tapa	1	EPDM	EN 681-1
7	Anillo de sujeción	1	X 12 CrNi 17-7	DIN 17224
8	Arandela de sujeción	1	Bronce Rg 5	DIN 1705
9	Junta tórica empaquetadura	2	NBR	ASTM D2000
10	Tornillo cuerpo tapa	2 (*4)	Acero 8.8 (con recubrimiento GEOMET)	DIN 912
11	Junta tórica eje*	1	EPDM	EN 681-1
12	Tuerca prensa*	1	Latón	
13	Junta tórica tuerca prensa*	2	NBR	ASTM D2000
14	Guardapolvos*	1	EPDM	
15	Tuerca sujeción cierre*	1	CW721R	EN 12165

* Para DN40/50.

PN-10/16 DN-20/50 (3/4" - 2")

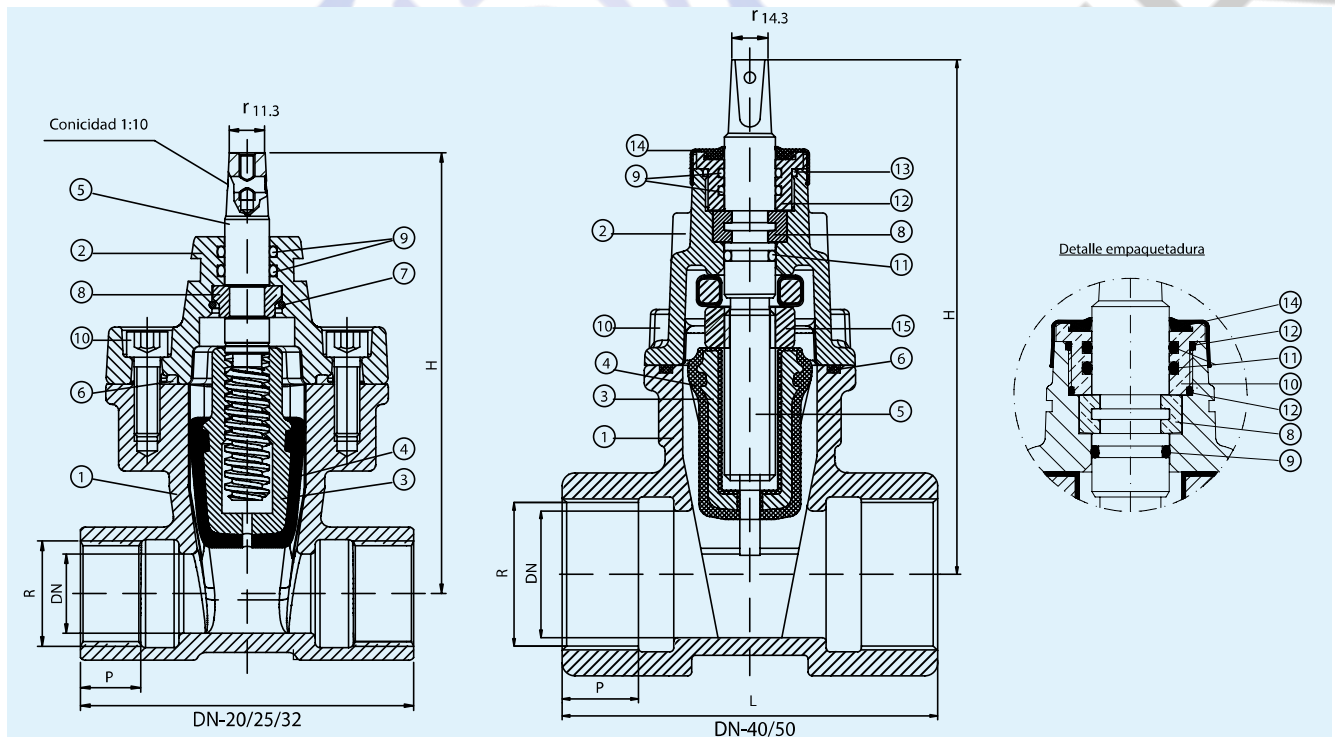

Diam.Ext.Tubo	R (B.S.P.)	L	P	H	Nº vueltas para cierre
25	3/4"	95	15	137	5
32	1"	105	19	139	6.5
40	1 1/4"	120	24	143	8
50	1 1/2"	130	29	192	10
63	2"	150	39	202.5	12.5